



CLA-VAL CPC

Position Control 4-20 mA

Simple, Reliable & Accurate

Pressure Management

Ideal for Pressure Management & Modulation

Pressure, Level or Flow Control, Retrofit

Easy interfacing to SCADA
4-20 mA

Extended Electronic Protection

IP68 Submersible

Motor 24 VDC and Powered
6 W only!

Innovation Since 1936

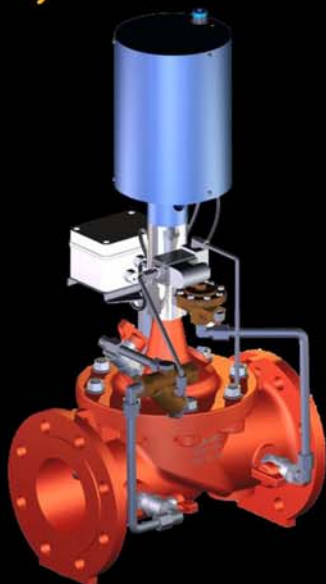

www.cla-val.ch

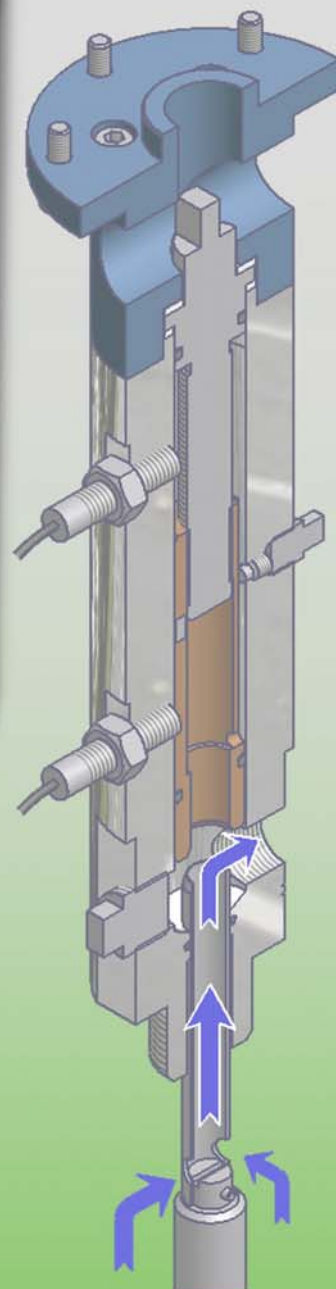

Valve Professionals will also require:

- GSM/Bluetooth communication
- Self-powered Units
- Data acquisition
- Internet data management

Great reasons to contact CLA-VAL!

► Simple, Reliable and Accurate



● Key Points and Description

- **Accurate 4-20 mA Position Control Actuator**
- **Pressure, Level or Flow Control**
- **Easy interfacing to SCADA 4-20 mA**
- **Submersible (IP-68)**
- **Extended Electronic Protection**
- **Motor 24 VDC and powered with only 6 W!**

The CLA-VAL CPC SERIES includes all valves with the Electronic Position Actuator. CPC provides accurate remote 4-20 mA set-point adjustments and can adjust pressure, flow or even reservoir level by positioning the valve precisely and smoothly between the fully closed and the fully open position.

Used for large water supply systems, transport pipelines or industrial applications the CLA-VAL CPC position control is a Hydraulic Actuator combined with Electronic « brushless » Motor Technology.

The CPC Actuator adjusts valve operating position by controlling its lift, using hydraulic forces present in the main valve, it creates a balance between inlet, outlet and cover chamber pressure. Valve inlet water pressure enters in the valve cover chamber through a calibrated fixed orifice. Water flows out of cover chamber to valve outlet through the stem tube and a variable orifice as illustrated in (Fig. 1). The variable orifice size is adjusted only by the CPC orifice coupling (coloured brown on Fig. 1) by the «brushless» motor, inducing the opening or the closing of the main valve. The single positioning of the orifice coupling is completely independent of the main valve diaphragm assembly and will produce identical positioning of the main valve diaphragm assembly, regardless of the system pressure.

As shown in (Fig. 1) there is no mechanical link between the orifice coupling and the valve stem, which are operating as a servo-piston unit. Consequently the «brushless» motor provides frictionless operation together with a very low power consumption of 6 W to move (at an adjustable speed) the orifice coupling up or down to reach any prescribed valve position, Security sensors and loss signal mode are integrated in the motor assembly.

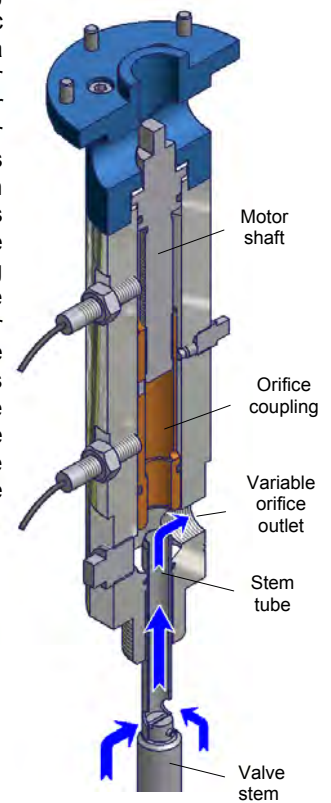

Fig. 1

► How does a Hydraulically Balanced Actuator Regulate?

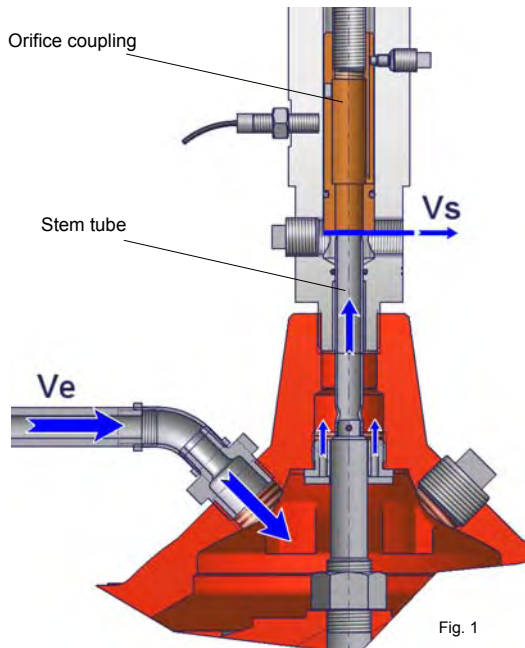

Fig. 1

Valve Closing (Fig. 1)

The «brushless» motor drives the orifice coupling downwards towards the requested set point which in turn decreases the variable orifice size. Subsequently less and less water discharges from the cover chamber to the valve outlet (**Vs**). Water flowing from the valves inlet port (**Ve**) enters the valve cover chamber via the calibrated fixed orifice which becomes increasingly greater than **Vs** generating the downward motion of the diaphragm assembly. This closes the valve to the prescribed set point corresponding to the analogical [4-20 mA] signal transmitted to the «brushless» motor. The displacement of water from the main valve diaphragm assembly is performed purely hydraulically, and there is no mechanical connection between the orifice coupling and the valve stem.

In the set position, the inlet water **Ve** balances the discharge water **Vs**, which explains why any in-balance between these two values permits an immediate and smooth reaction which delivers a smooth motion of the internal diaphragm assembly.

In the completely closed position, the leakage created by the mechanical tolerance between the orifice coupling and the stem tube is stopped drip tight at the outlet of the Electronic Position Actuator CPC by a separate solenoid valve installed in its discharge line.

Valve Opening (Fig. 2)

The «brushless» motor drives the orifice coupling upwards to the requested set point which in turn increases the variable orifice size. Subsequently, more and more water is discharged from the main valve cover chamber to the valve outlet (**Vs**). Water entering into the valve cover **Ve** via the calibrated orifice is not compensating for the water leaving the top cover via **Vs**. This permits the diaphragm assembly to move upwards which opens the valve to the prescribed set-point corresponding to the analogical [4-20 mA] signal transmitted to the «brushless» motor. The displacement of the main valve diaphragm assembly is performed purely hydraulically, since there is no mechanical connection between the orifice coupling and the valve stem.

In the set position, the inlet water **Ve** is balancing the water discharged via **Vs**, which explains why any in-balance between these two values permits an immediate and smooth reaction which delivers a smooth motion of the internal diaphragm assembly.

Due to these CLA-VAL features both pressure differential values [valve inlet ⇒ cover chamber] or [cover chamber ⇒ valve outlet] are identical therefore any change of pressure in the system does not affect the set position of the main valve.

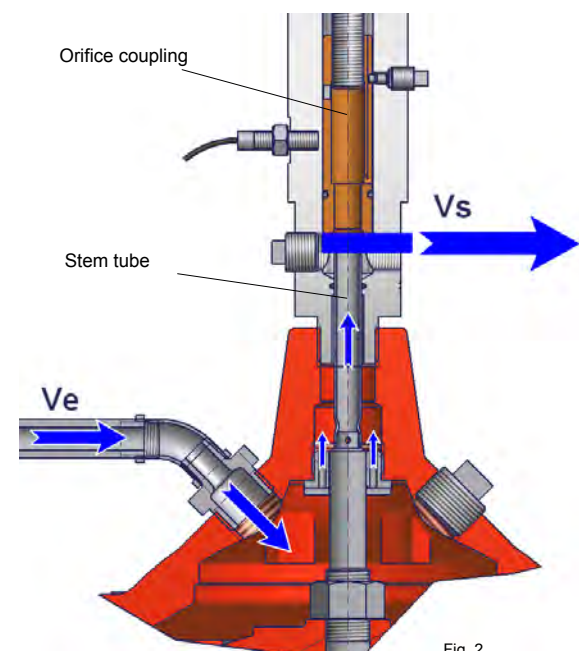

Fig. 2

▶ Actuated Position Control 4-20 mA features

Design: The CLA-VAL CPC Actuated Position Control is designed for continuous position control. The CLA-VAL CPC can be assembled on all CLA-VAL valves up to GE300/NGE400 with specific speed adjustment. Refer to specific datasheet for more information.



Software: User friendly CLA-VAL Calibration Software provides simple to program control features. 4-20 mA range settings are directly entered to match desired flow or level values. The graphic interface is self explanatory and offers a very simple way to calibrate precise control values.

Internet Updates: All software updates are free and available on the CLA-VAL web site.

PC Connection: Plugged directly in your PC USB port or by Bluetooth e-Drive parameters and data are instantly accessible through the calibration software.

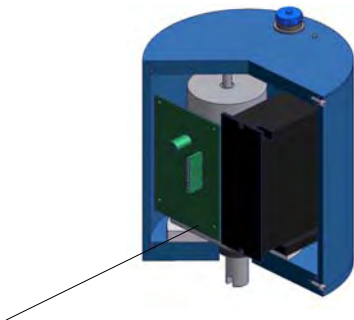

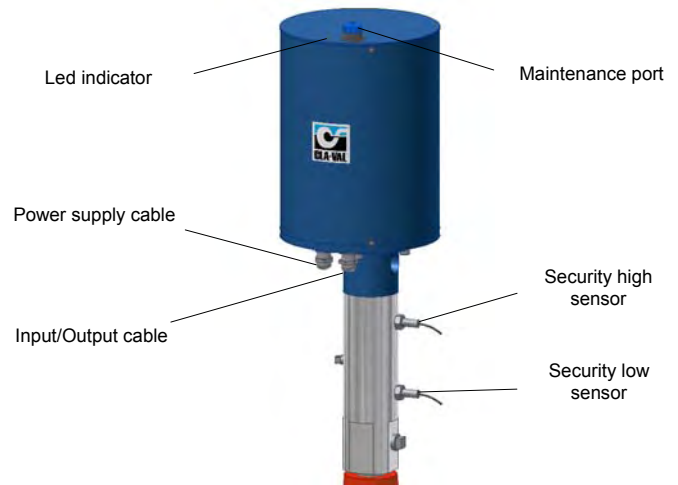

PCB (Printed Circuit Board): Is build with the latest technologies including high quality components. The input is insulated (2 wires) and isolated to protect against signal interference (common mode rejection up to 1000 V). A resettable fuse is used to protect against over voltage / reverse polarity. To prevent condensation (humidity protection), heater starts when internal temp falls below 5°C, the PCB includes also tropical coating for moisture protection. The position low and high is protected automatically cuts power to prevent mechanical damage without loss of original calibration. The Brushless motor is made for continuous duty, higher efficiency and reliability.

MEXUSB20401A cable and MEXUSBADAPT is required for programming and monitoring



▶ Technical data:

	Electrical Specifications
Electrical Power:	<ul style="list-style-type: none"> • 24 VDC, 6 / 10 / 15 rpm / sizes 300 mA max. load draw
Power Protection:	<ul style="list-style-type: none"> • 85 mA stand-by (no load draw)
Led display:	<ul style="list-style-type: none"> • Max. 32 VDC over voltage
Electrical connection:	<ul style="list-style-type: none"> • Max. 1000 mA torque load
Input command:	<ul style="list-style-type: none"> • Reverse polarity & short circuit
Input 4-20 mA Protection:	<ul style="list-style-type: none"> • 80°C stop @ high temperature
Output feedback:	<ul style="list-style-type: none"> • Green led
Output 4-20 mA Protection:	<ul style="list-style-type: none"> • 2 x Moulded 10 m cables
Input 4-20 mA Protection:	<ul style="list-style-type: none"> • 2 x dry contact (contact security)
Output feedback:	<ul style="list-style-type: none"> • Max. 32 VDC over voltage
Output 4-20 mA Protection:	<ul style="list-style-type: none"> • Optocoupler isolation @ CMR 1000 V (CMR: common mode rejection)
Input 4-20 mA Protection:	<ul style="list-style-type: none"> • Insulated (2 wires)
Output feedback:	<ul style="list-style-type: none"> • 4-20 mA (Output charge ≤ 500 Ω)
Output 4-20 mA Protection:	<ul style="list-style-type: none"> • 2 x programmable position alarms 24 VDC / 240 VAC up to 1 A max.
Input 4-20 mA Protection:	<ul style="list-style-type: none"> • Max. 32 VDC over voltage
Output feedback:	<ul style="list-style-type: none"> • (The input dry contact and 4-20 mA output have the same common or earth but are not individually isolated)
	Other Specifications
Sizes:	<ul style="list-style-type: none"> • GE 50 - 300 / NGE 80 - 400
Operating Pressure:	<ul style="list-style-type: none"> • PN 16 bar standard
Temperature range:	<ul style="list-style-type: none"> • -10°C to +80°C.
Rating:	<ul style="list-style-type: none"> • IP68 standard allowing full immersion (solenoid, junction box, sensor, not included in IP68)
Interface:	<ul style="list-style-type: none"> • Plug & Play / NT / 2000 / XP / Vista / Win 7
	Default mode
Troubleshooting:	<ul style="list-style-type: none"> • Refer to user manual for LED diagnostics and codes: red-green-blinking
Remote command failure:	<ul style="list-style-type: none"> • Options available: maintain current position, go to 4 mA position, go to 20 mA position

► 4 Typical applications of the CLA-VAL series CPC

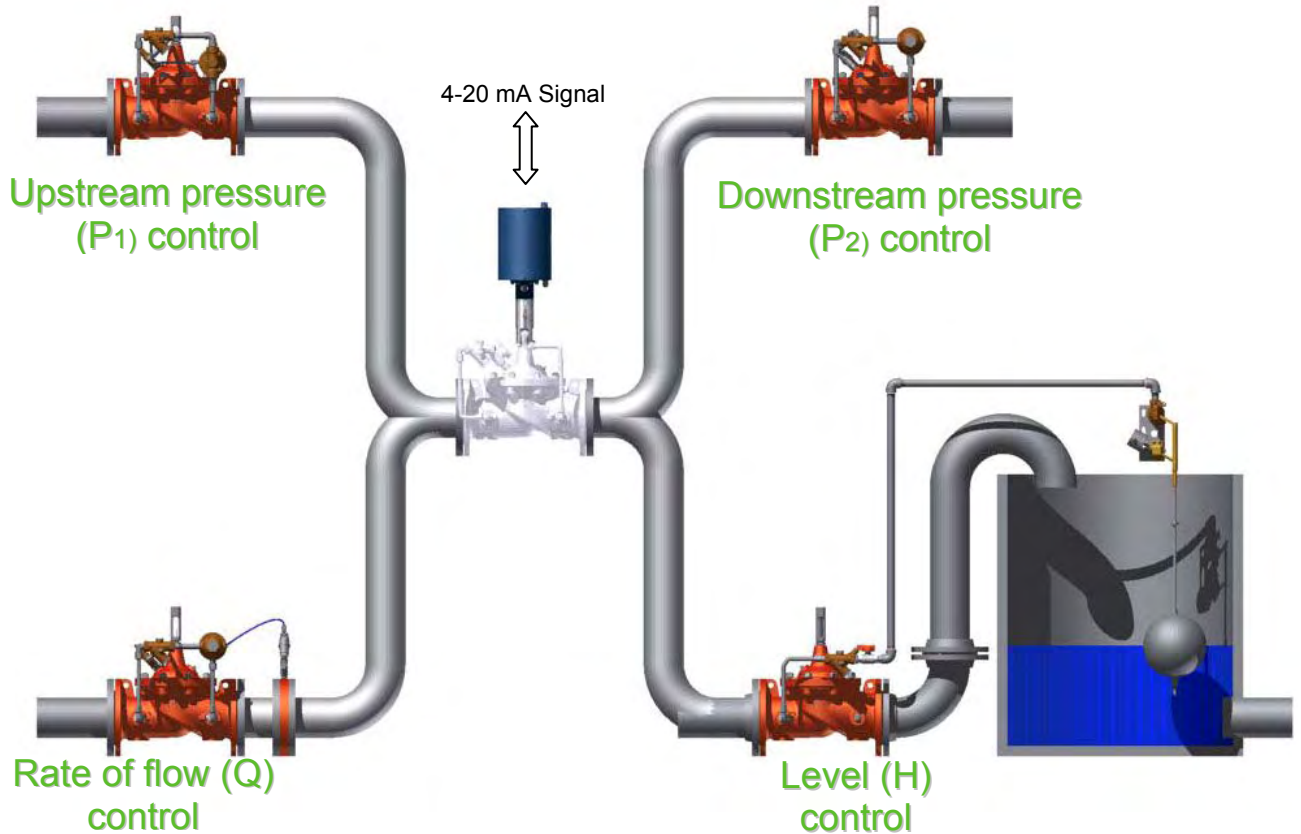

The CLA-VAL CPC SERIES receives a remote analogical signal [4-20 mA] over a SCADA system or equivalent. This signal will act directly on the «brushless» motor, which will drive the orifice coupling until it reaches its corresponding set value.

The CPC Actuator is particularly recommended if the user intends to apply a hydraulically operated control whilst maintaining the flexibility to change its respective set value at anytime. The applications are numerous considering the various parameters of a hydraulically operated system, whose four key applications are illustrated above and can be listed as follows :

Inlet pressure control - Outlet pressure control - Rate of flow control - Level control

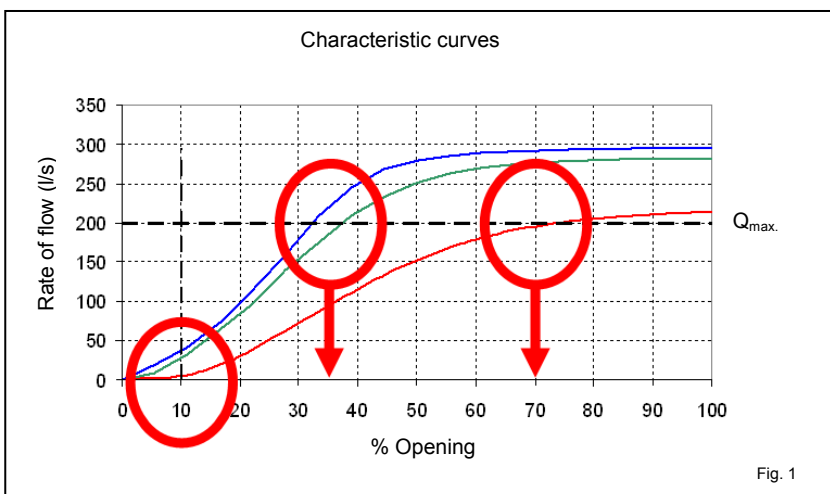

The CLA-VAL CPC main valve offers a characteristic curve extremely well adapted to a regulating process within a SCADA supervision system.

In fact Fig. 1 illustrates the characteristic curves of a butterfly (green) and ball (blue) valve, as well as the one of the CPC (red) main valve. This demonstrates that the CLA-VAL CPC curve offers on one hand a **much wider regulating range** than the two other and on the other hand a **low opening value at small rate of flow**. These two conditions are the key factors for any progressive, accurate and sensible regulating operation which allows the CLA-VAL CPC to offer such a wide application range.

► 4 Typical applications for the SERIES CLA-VAL CPC

Remote Set Point

The CPC actuator receives an analogical signal (4-20 mA) from a SCADA system and automatically adjusts the «brushless» motor until the valves position reaches the prescribed set point.

The CPC actuator is particularly recommended for applications where the user wishes to keep a hydraulically operated system with the ability to change the set-point of the valve. Applications are numerous depending on the types of the parameters chosen.

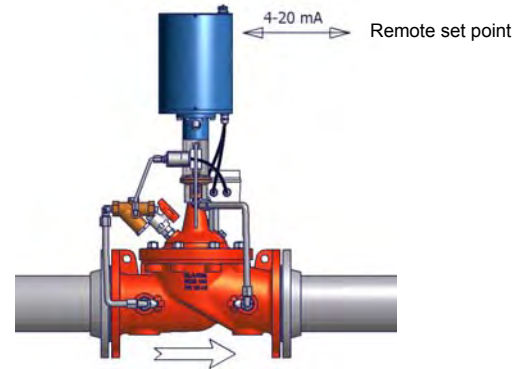

Local Set Point

The CPC Actuator working together with an e-Smart/L2 electronic controller provides automatic control of the system. E-Smart/L2 compares local feed-back signal with pre-programmed conditional set-points and adjusts the valves position automatically until set-point is reached.

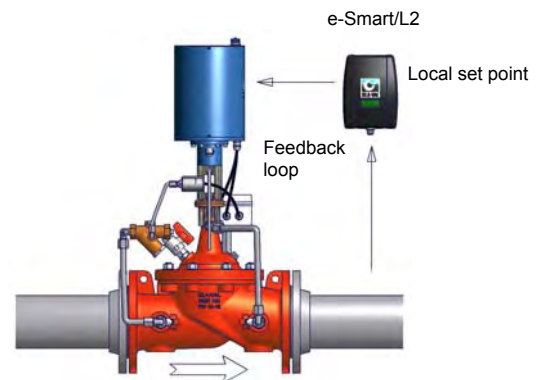

Hydraulic Safety

In most CPC Actuator applications, it is possible to secure its operation during electrical power failure by additional hydraulically operated CLA-VAL pilot(s) which are added to its pilot circuit. These allow the valve to maintain a safety value. E.g Pressure reducing, pressure sustaining or maximum rate of flow until power is restored.

The above combination offers the advantage of not only controlling the valve in the event of electrical power failure, but to increase the flexibility of the CPC Actuator application, by adding to the basic operation other hydraulically operated functions. These additional features for the SERIES CLA-VAL CPC are highly appreciated in applications where other variables have to be regulated during power failure.

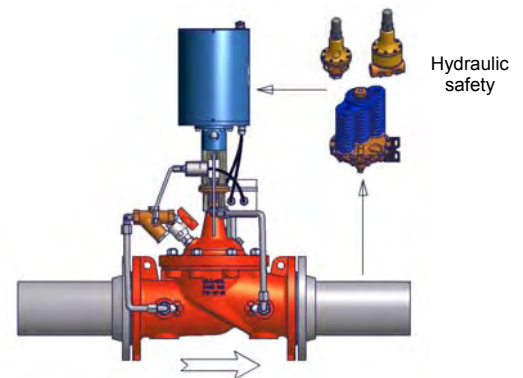

Autonomous Turbine

A particular feature of the CPC Actuator is its very low power consumption with a voltage of 24 VDC. CLA-VAL has therefore taken advantage of this and developed an autonomous turbine hydraulically installed as bypass of the CPC Actuator operated valve. The turbine can feed the CPC Actuator electrical motor and eventually any other low power users, as transmission of data or specific information.

The autonomous turbine, is mounted in bypass of the valve, is producing 0,5 A at 24 VDC and works in parallel with a battery, permitting actuation of the CPC motor.

