



# CLA-VAL e-Drive-33

## Pilot Control 4-20 mA

Simple, Reliable & Accurate

### Pressure Management

Ideal for Pressure Management & Modulation

Pressure, Level or Flow Control, Retrofit

Easy interfacing to SCADA 4-20 mA

Extended Electronic Protection

IP68 Submersible

Motor 12-24 VDC and Powered 6 W only!

*Innovation Since 1936*

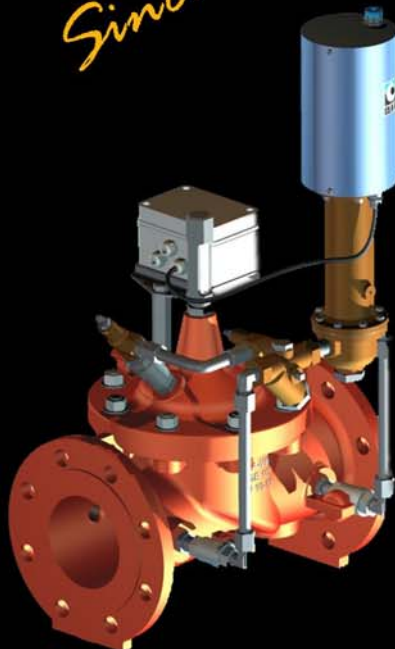
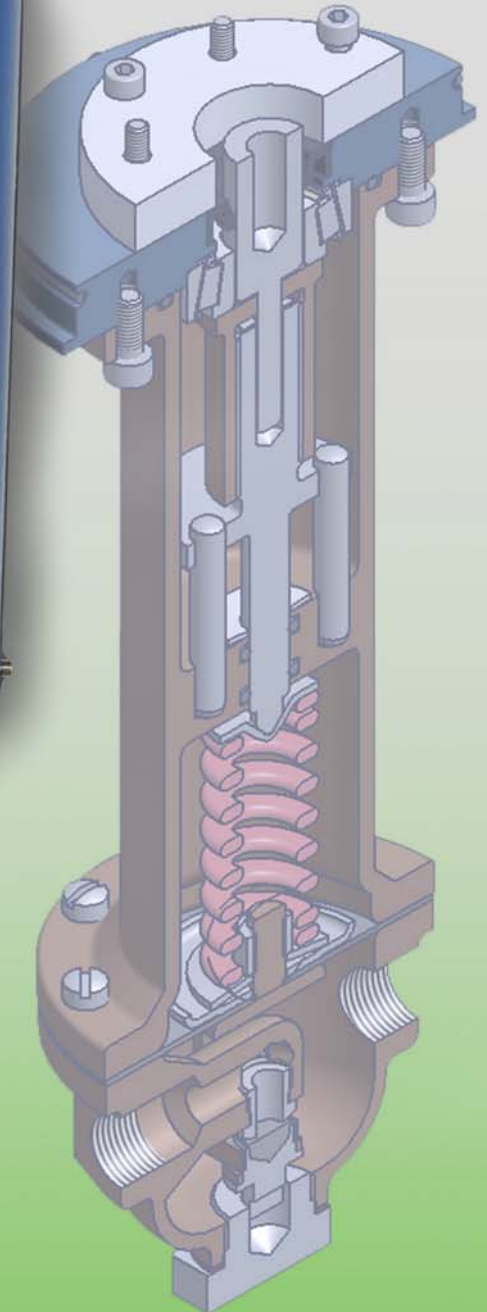

Valve Professionals will also require:

- GSM/Bluetooth communication
- Self-powered Units
- Data acquisition
- Internet data management

Great reasons to contact CLA-VAL!

### ► Simple, Reliable and Accurate



#### ► Key Points and Description

- **Ideal for Pressure Management & Modulation**
- **Pressure, Level or Flow Control**
- **Easy interfacing to SCADA 4-20 mA**
- **Submersible (IP-68)**
- **Extended Electronic Protection**
- **Motor 24 VDC and powered 12 W only at 20 bar!**

The CLA-VAL PCM SERIES includes all valves with the Electronic Actuated Pilot Control e-Drive-33 providing accurate remote set-point adjustments. Combining traditional hydraulic pilot controls with the e-Drive-33 actuator interfaces smoothly existing and traditional water systems with SCADA capabilities.

The CLA-VAL PCM SERIES allows remote set-point command signals from any SCADA control system using a 4-20 mA signal.

The e-Drive-33 Actuator adjusts all CLA-VAL Pilot Controls by changing the pressure load on the pilot springs (in red on Fig.1). The e-Drive-33 is a 24 VDC motorised actuated turning clockwise or anti-clockwise to alter spring pressure setting. As water flows through the pilot control body across the seat (grey in Fig.1) to the downstream of the valve, the pilot control, spring loaded by the e-Drive-33 actuator, senses pressure or flow in the same manner as a traditional-hydraulic CLA-VAL Control Pilots. A remote 4-20 mA set-point signal adjustment will allow the valve to deliver a new pressure or flow downstream within preset limits. Pressure and flow settings are linear between these settings.

The mechanical upper-assembly has one upper-chamber incorporating high precision bearings designed to last millions of cycles. The lower-chamber is similar to all CLA-VAL control pilots including the spring and diaphragm sub-assembly for precise control.

The e-Drive-33 actuator operates on 24 VDC (12 VDC optional) consuming very little power (12 W) ideal control for remote sites with a micro-turbine. Factory calibrated the e-Drive-33 remains in automatic control assuring system stability under all conditions.

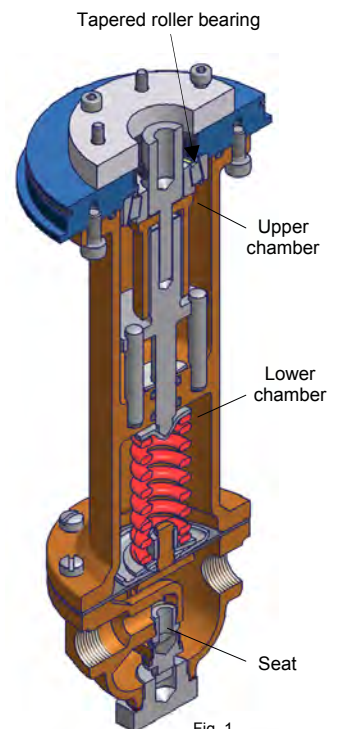
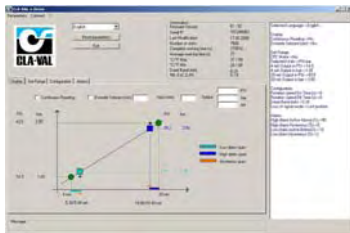

Fig. 1

### ▶ Actuated Pilot Control 4-20 mA Features

**Design:** The CLA-VAL e-Drive-33 Actuated Pilot Control is designed for 500 actions/day changes in remote set-point (average one action every 3 minutes) and fully cycle tested for over more than 1'000'000 motor actions.

The CLA-VAL e-Drive-33 can be assembled on all CLA-VAL standard pilot controls such as CRD - CRL - CDHS - CDB. Refer to specific datasheet for more detailed information.



**Software:** User friendly CLA-VAL Calibration Software provides simple to program control features. 4-20 mA range settings are directly entered to match desired flow or level values.

The graphic interface is self explanatory and offers a very simple way to calibrate precise control values.

**Internet Updates:** All software updates are free and available on the CLA-VAL web site.

**PC Connection:** Plugged directly in your PC USB port or by Bluetooth e-Drive-33 parameters and data are instantly accessible through the calibration software.

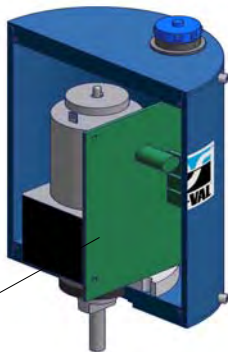

**PCB (Printed Circuit Board):** Is build with the latest technologies including high quality components. The input is insulated (2 wires) and isolated to protect against signal interference (common mode rejection up to 1000 V). A resettable fuse is used to protect against over voltage / reverse polarity. To prevent condensation (humidity protection), heater starts when internal temp falls below 5°C, the PCB includes also tropical coating for moisture protection. The position is sensed by hall effect sensor with no mechanical contact therefore avoiding all wear and tear problems caused by vibration and continuous operation.

MEXUSB20401A cable and MEXUSBADAPT is required for programming and monitoring.

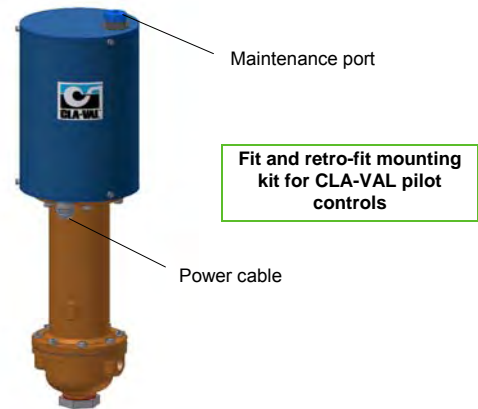

### ▶ Technical Data



#### Electrical Power:

#### Electrical Specifications

- 24 VDC, 6 rpm rated speed
- 12 VDC, 3 rpm rated speed
- 300 mA max. load draw @ 20 bar
- 30 mA stand-by (no load draw)

#### Power Protection:

Max. 32 VDC over voltage  
Max. 800 mA torque load draw  
Reverse polarity & short circuit  
80°C stop @ high temperature

#### Led display:

Green led

#### Electrical connection:

Moulded 10 m cables

#### Input command:

- 4-20 mA (2 wires)
  - 2 x dry contact (manual positioning)
- Max. 32 VDC over voltage  
Optocoupler isolation @ CMR 1000 V  
(CMR: common mode rejection)  
Insulated (2 wires)

#### Input 4-20 mA Protection

#### Output feedback:

- 4-20 mA (output charge ≤ 500 Ω)
- 2 x programmable position alarms  
24 VDC / 240 VAC up to 1 A max.

#### Output 4-20 mA Protection

Max. 32 VDC over voltage  
(The input dry contact and 4-20 mA output have the same common or earth but are not individually isolated)



#### Operating Pressure:

#### Other Specifications

PN 16 bar standard

#### Temperature range:

-10°C to +80°C

#### Rating:

IP68 standard allowing full immersion (Solenoid, junction box, sensor, not included in IP68)

#### Interface:

Plug & Play / NT / 2000 / XP / Vista / Win 7



#### Troubleshooting:

#### Default mode

Refer to user manual for LED diagnostics and codes: red-green-blinking

#### Remote command failure:

Options available: maintain current position, go to 4 mA position, go to 20 mA position

### ▶ 4 Typical Applications of the CLA-VAL series PCM

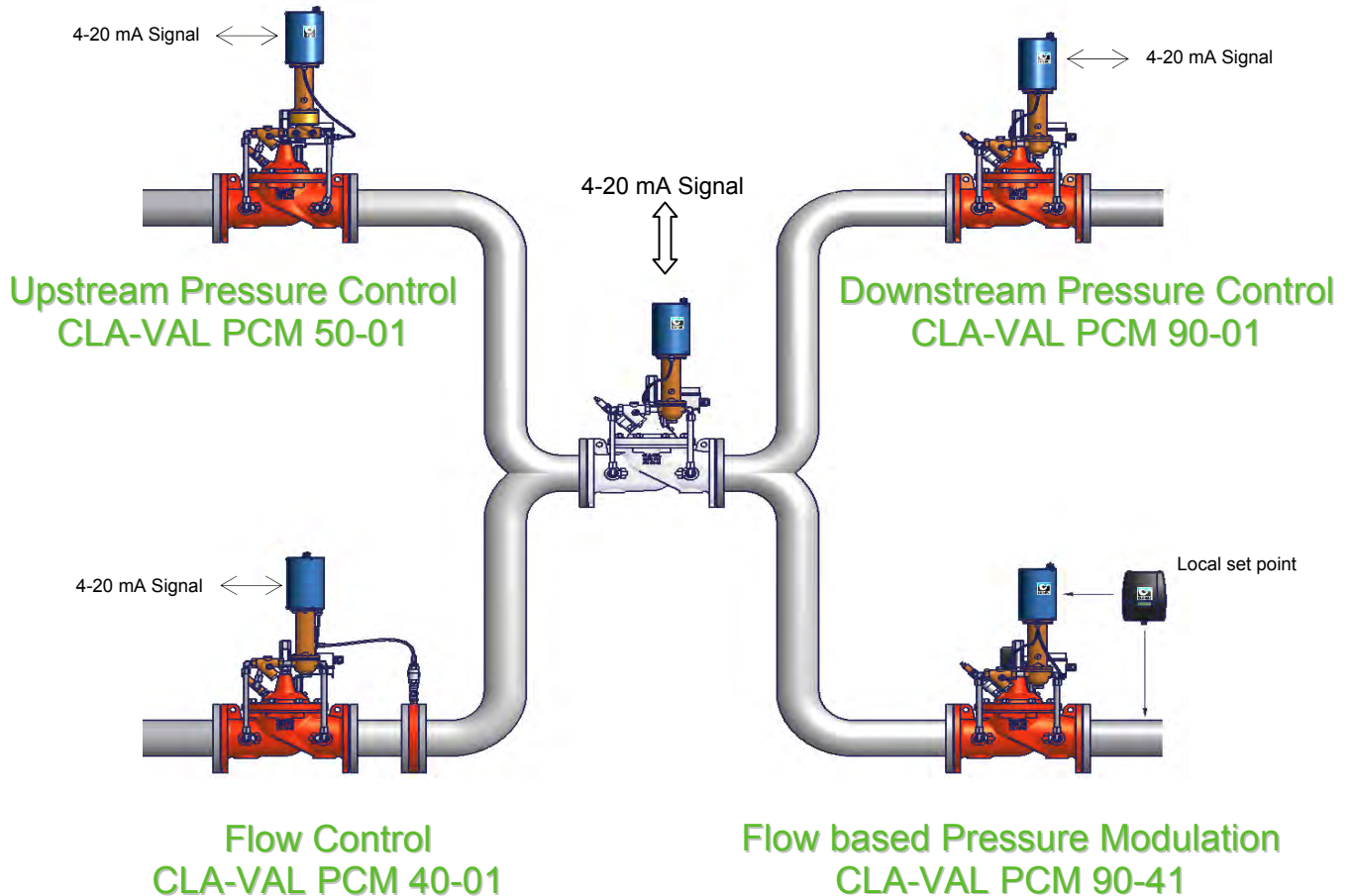

The e-Drive-33 Actuator accepts a 4-20 mA remote set-point from a customer supplied pressure or flow sensor via a local SCADA-type system. The 4-20 mA remote set-point turns the e-Drive-33 Actuator clockwise or anti-clockwise positioning the CLA-VAL pilot control to maintain a new pressure or flow set point.

The e-Drive-33 Actuator is a very effective solution within systems where the user would like to keep full hydraulic control (particularly is disrupted) but also requires from time to time, a remote set-point change. Combining electronic and traditional hydraulic pilots is a great solution when systems have fast hydraulic responses. The various CLA-VAL pilots keep the valve under total automatic control regardless of pressure and/or flow fluctuations which act on the pilot diaphragms leaving the PLC to issue set points only. Therefore a motorised CLA-VAL valve keeps the same regulation abilities as traditional non-motorised valves. There is no need for any type of system analysis in terms of actuated pilot and valve reaction and efficiency.

All CLA-VAL Actuated Pilot Controls accept 4-20 mA remote set-points within preset limits. Pressure or flow calibration is dependant on the spring range. Pressure settings are linear between these settings. Special USB connector cable and free downloadable software from [www.cla-val.eu](http://www.cla-val.eu) can be used to change this setting range if needed. Continuous internal monitoring of actuator position results in smooth transitions between pilot set-points with no backlash or dithering.

Should power or control input fail, all CLA-VAL Actuated Pilots will remain in automatic hydraulic control (at the last set-point) assuring system stability under all conditions.

### ► 4 Typical Applications of the CLA-VAL series PCM

#### CRD-33 (CRA-33)

The CRD-33 Actuated Pilot Control provides accurate downstream pressure control. In addition to the same functionality as the CRD-33 the CRA-33 senses a remote hydraulic pressure with a remote hydraulic connection. Remote set-point command signals can be from any SCADA-type supervision system using a 4-20 mA signal.

Actuated pilots are an effective solution for pressure management and modulation within existing networks. Easy to program the CRD-33 / CRA-33 series lower pressure during night time and optimises pressure during daytime.

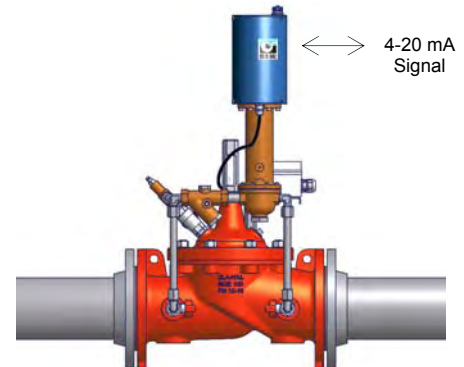

#### CRL-33

The CRL-33 Actuated Pilot Control senses upstream pressure with a remote hydraulic connection. Remote set-point command signals can be from any SCADA-type supervision system using a 4-20 mA signal.

This actuated pilot is installed on valves that maintain minimum upstream pressure by relieving excess pressure to a lower pressure zone and require remote pressure adjustment. Operating on 24 VDC and consuming very little power it is an ideal control system for remote valve sites where the set-point command needs to be adapted on a regular basis.

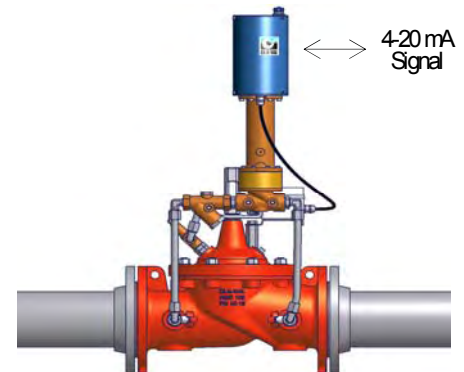

#### CDHS-33

The CDHS-33 Actuated Pilot Control senses an accurate differential pressure with a remote hydraulic connection. Remote set-point command signals can be from any SCADA-type supervision system using a 4-20 mA signal.

A precision orifice plate installed downstream of the valve creates differential pressure used for rate of flow control by the CDHS-33.

This actuated pilot is installed on valves that maintain flow rate and require this flow to be changed from a remote location. Depending on both orifice size and spring range the CHDS-33 can alter flow set-point over a wide range.

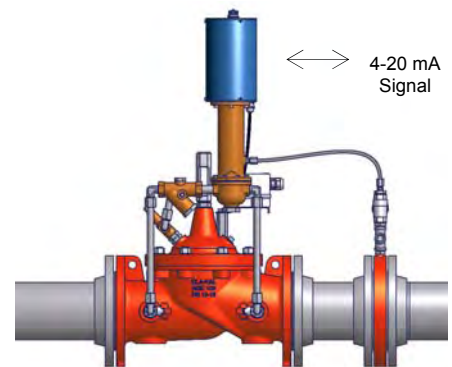

#### e-Drive-33 / e-Smart/L2 / Turbine

Combining the Actuated Pilots -33 with the CLA-VAL e-Smart/L2 PLC is an effective solution to create custom correlation between pressure and flow information in a on-site feedback loop.

All energy requirements can be covered by adding a CLA-VAL turbine on the valve by-pass or even add a solar panel - 24 V 12 W.

